

THE HABITABLE WORLDS OBSERVATORY ENGINEERING VIEW: STATUS, PLANS AND OPPORTUNITIES

LEE.D.FEINBERG^A, JOHN ZIEMER^B, MEGAN ANSDEL^C, JULIE CROOKE^C, COURTNEY DRESSING^D, BERTRAND MENNESSON^B, JOHN O'MEARA^E, JOSHUA PEPPER^C, AKI ROBERGE^A

^A GODDARD SPACE FLIGHT CENTER, GREENBELT, MARYLAND 20771; ^B JPL; ^C NASA HQ; ^D UCB; ^E KECK

SPIE Yokohoma, June 16th, 2024

H A B I T A B L E
W R L D S
O B S E R V A T O R Y

TOPICS

- **INTRODUCTION**
- **APPROACH**
- **EXPLORATORY ANALYTIC CASES (EAC'S) AND CORONAGRAPH EXPLORATORY CASES**
- **PARAMETER STUDIES**
- **TECHNOLOGY MATURATION APPROACH**
- **APPROACH TO SCIENCE AND ENGINEERING INTERFACE**
- **CONCLUSIONS**

HWO WORK HAS BEEN GUIDED BY THE **START & TAG**

Science, Technology, Architecture Review Team (START)

- Quantify HWO's science objectives using Astro2020's guidance
- Outline the observatory and instrument capabilities needed to accomplish those goals.
- Develop the science goals and objectives portions of the Science Traceability Matrix.
- Assess the fidelity of models needed in the future to execute future trades.

Technical Assessment Group (TAG)

- Study architecture options – 3 Exploratory Analytic Cases, Parameter Studies
- Use Architectures and Parameter Studies to Help Define Technology Needs
- Develop Technology Roadmaps and Plans
- Evaluate the risks associated with options
- Explore the trade space

THE **START** & **TAG** ARE LED BY THE GIG (GOMAP INTEGRATION GROUP)



Julie Crooke
(NASA HQ)
Program
Executive

Megan Ansell
(NASA HQ)
Program
Scientist

Josh Pepper
(NASA HQ)
Deputy
Program
Scientist

Courtney
Dressing
(University of
California,
Berkeley)

John O'Meara
(Keck
Observatories)

Lee Feinberg
(NASA GSFC)

Bertrand
Mennesson
(NASA JPL)

Aki Roberge
(NASA GSFC)

John Ziemer
(NASA JPL)

NASA Headquarters (HQ)

START Co-Chairs

TAG Co-Chairs

START MEMBERSHIP

Giada Arney	GSFC
Natasha Batalha	Ames
Eric Burns	Louisiana State University
Jessie Christiansen	NExSci
Courtney Dressing (Co-Chair)	UC Berkeley
Kevin France	CU Boulder
Scott Gaudi	Ohio State University
Renyu Hu	JPL
Alina Kiessling	JPL
Janice Lee	STScI
Bruce Macintosh	UC Observatories

John O'Meara (Co-Chair)	W. M. Keck Observatory
Jim Oschmann	Marinus Consulting
Rachel Osten	STScI
Chris Packham	UT San Antonio
Lynnae Quick	GSFC
Jason Rhodes	JPL
Jane Rigby	GSFC
Ty Robinson	University of Arizona
Dmitry Savransky	Cornell University
Evan Scannapieco	Arizona State University
Evgenya Shkolnik	Arizona State University

START EX-OFFICIO MEMBERSHIP

Name	Institution
Charlie Atkinson	Northrop Grumman
Matthew East	L3Harris
Alison Nordt	Lockheed Martin
Erik Wilkinson	Ball Aerospace

Name	Institution
Eric Mamajek	ExEP
Swara Ravindranath	COR

Name	Institution
Miyazaki Satoshi	JAXA / NAOJ
Takahiro Sumi	JAXA / Osaka
Ana Gomez de Castro	ESA / Madrid
Michiel Min	ESA / Amsterdam
David Mouillet	ESA / Grenoble
Christian Marois	CSA / NRC-Herzberg

TAG MEMBERSHIP

Ruslan Belikov	Ames
Matthew Bolcar	GSFC
Jason Derleth (ex-officio)	COR
Lee Feinberg (Eng. Co-Chair)	GSFC
Kevin Fogarty	Ames
Jessica Gaskin	MSFC
Thomas Greene	Ames
Brian Kern	JPL
Marie Levine	JPL
Alice Liu	GSFC
Sangeeta Malhotra	GSFC
Dimitri Mawet	JPL
Michael McElwain	GSFC
Bertrand Mennesson (Sci. Co-Chair)	JPL

Michael Menzel	GSFC
Patrick Morrissey	JPL
Niki Parenteau	Ames
David Redding	JPL
Aki Roberge (Sci. Co-Chair)	GSFC
Stuart Shaklan	JPL
Nick Siegler (ex-officio)	ExEP
Breann Sitarski	GSFC
Philip Stahl	MSFC
Christopher Stark	GSFC
Julie van Campen	GSFC
Feng Zhao	JPL
John Ziemer (Eng. Co-Chair)	JPL
TBA member - deferred start date	JPL

Big Picture Drivers:

CONCEPT MATURITY LEVELS (CML)

for NASA Competed and Assigned Projects

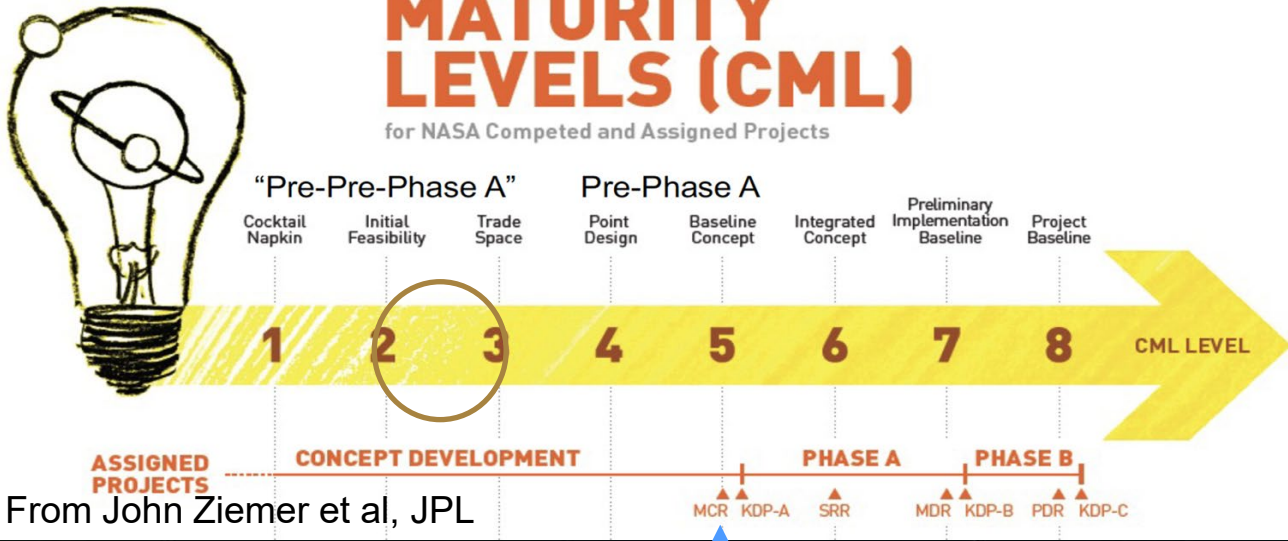

GOAL IS MCR BY 2030

MCR Requirements via GSFC – STD – 1001A

Table 3-2: MCR Success Criteria

Category	MCR Criteria
Review Process	A preliminary Systems Review Plan (SRP) including an Engineering Peer Review Plan (EPRP) is available and deemed compliant with all applicable requirements.
Technical Management	<p>Mission objectives are clearly defined and unambiguous.</p> <p>Potential technology needs are identified and the gaps between such needs and the current and/or planned technology readiness levels have been assessed with acceptable results.</p> <p>The evaluation criteria and trade space for candidate systems that fulfill the conceptual design requirements have been identified and prioritized.</p> <p>Technical planning is sufficient to proceed to the next phase.</p>
System Design and Demonstration	<p>An operations concept and system architecture is provided that meets these requirements, demonstrating the feasibility of the mission and technical solution.</p> <p>A search was conducted to identify existing assets or products that have a potential to be implemented to satisfy the mission or parts of the mission.</p> <p>The preliminary set of requirements meeting the objectives is provided and is consistently stated within the project.</p>
Safety & Mission Assurance	Safety and mission assurance activities (i.e., safety, reliability, maintainability, quality, and Electrical, Electronic and Electromechanical [EEE] parts) related to the mission and conceptual design have been adequately addressed.
Project Management	<p>Initial risk identification and mitigation strategies have been provided and are acceptable.</p> <p>A rough order of magnitude cost estimate is provided and is both credible and within an acceptable cost range.</p> <p>The schedule estimates are credible.</p>

From Mike Menzel

EXPLORATORY ANALYTIC CASES (EACs)

1st round mission architectures that will be used to **explore the HWO trade space**. Purposes ...

- Practice end-to-end modeling, from science to engineering. Develop initial models & codes to “pipeclean” the process using representative examples, understand end to end modeling capabilities and needs
- Use EACs to identify key technology gaps and guide maturation of potential technology solutions
- Explore key architectural options/breakpoints in the context of rockets to help guide future point design choices
- Provide feedback to rocket vendors as soon as possible to help influence their direction

**We don't expect any of the cases studied will become a baseline design going forward.
These are only intended to explore and practice.**

Early JWST



Final JWST
CML 9+



SAMPLE OF HOW EAC'S WILL ITERATE (MORE ON THIS LATER)

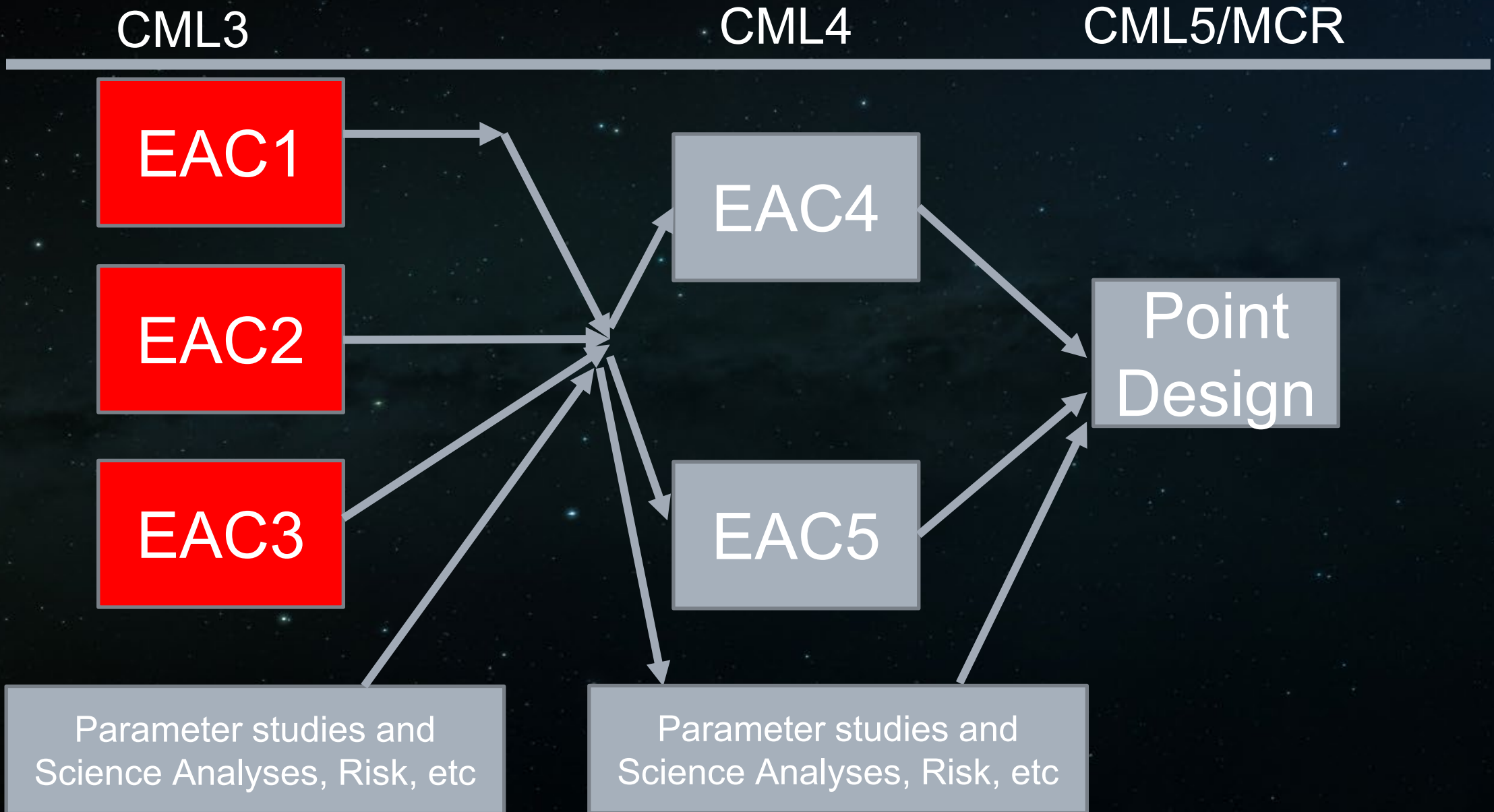

HWO PRELIMINARY SPECS & CANDIDATE INSTRUMENTS

Telescope

Diameter	6+ meters
Bandpass	100nm-2500nm
Diffr. Lim. Wavelength, Line of Sight	.5um, .4mas LOS

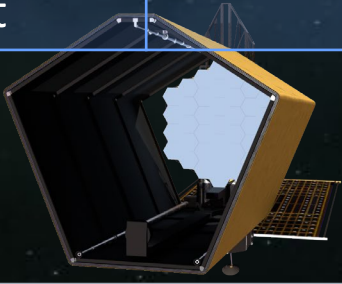

Fourth Instrument
To be defined

Coronagraph*

High-contrast imaging and imaging spectroscopy	
Bandpass	~400–1800 nm
Contrast	$\lesssim 1 \times 10^{-10}$
R ($\lambda/\Delta\lambda$)	Vis: ~140 NIR: ~70, 200

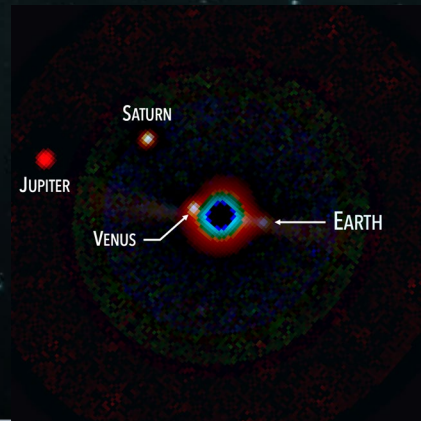

* High contrast NUV could be fourth instrument

High-Resolution Imager

UV/Vis and NIR imaging

Bandpass	~200–2500 nm
Field-of-View	~3' × 2'
~67 science filters + grism	
High-precision astrometry?	



UV Multi-Object Spectrograph

UV/Vis multi-object spectroscopy and FUV imaging

Bandpass	~100–1000 nm
Field-of-View	~2' × 2'
Apertures	~840 × 420
R ($\lambda/\Delta\lambda$)	500–50,000



LAUNCHER MASS AND VOLUME CAPABILITIES



NASA
Space Launch System



Space-X
Starship



Blue Origin
New Glenn

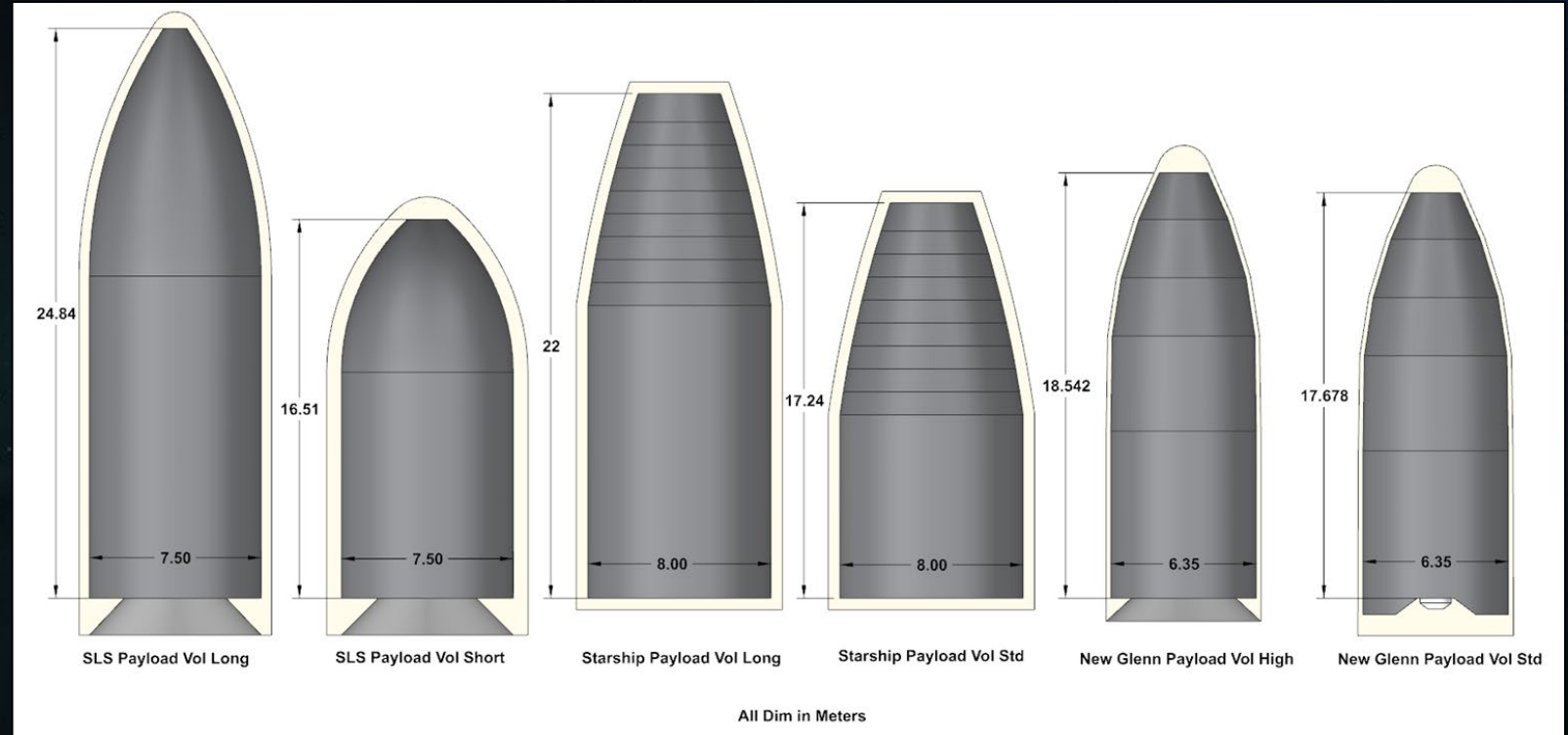

Roman Space Telescope started being compatible with 3 rockets. Only 1 was ready when Falcon 9H chosen

Currently studying Starship Standard and New Glenn

Launcher	Mass to L2 (kg)	Notes
Space-X Starship	100,000	Starship will require re-fueling in low earth orbit (and a fuel depot).
NASA Space Launch Systems (SLS)	44,300	Not currently building a large fairing.
Blue Origin New Glenn	15,000	First launch planned for 2024. More mass capability TBD.

Key Architecture Assumption: Micrometeoroids

Red dots are “flashes” from micrometeoroids (JWST)

Grey are pointings

Implemented Micrometeoroid Avoidance Zone to Minimize RAM Pointings

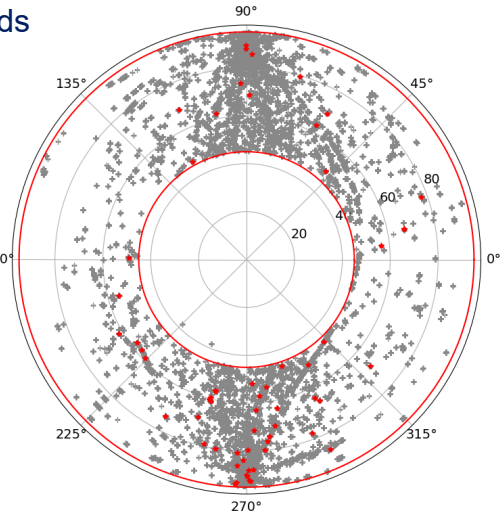

RAM Direction

Marcio Melendez/StSci

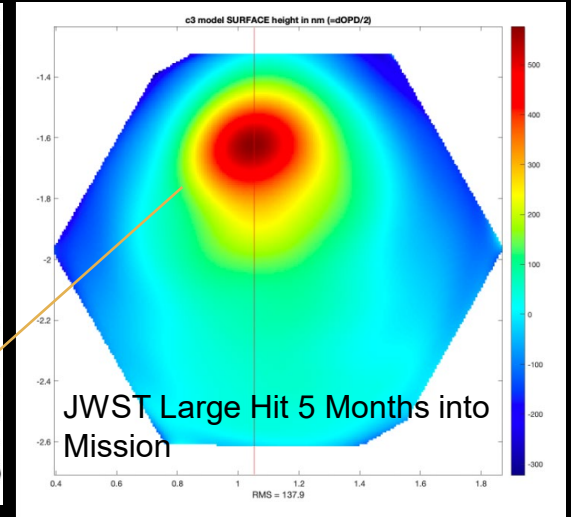
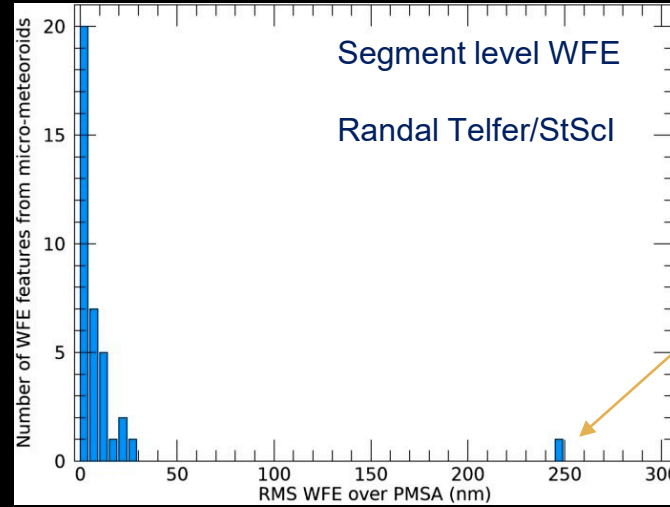

Segment WFE Changes for JWST Micrometeoroids after correction. Typically 2-3 per month

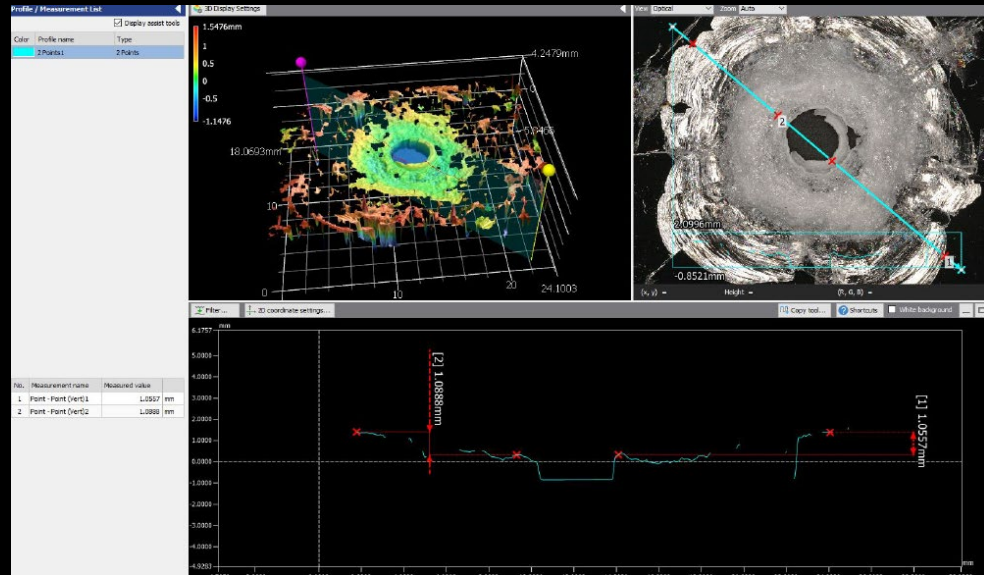

2mm thick ULE sample 7J hit

2mm thick ULE sample (T. Hadjimichael/GSFC)

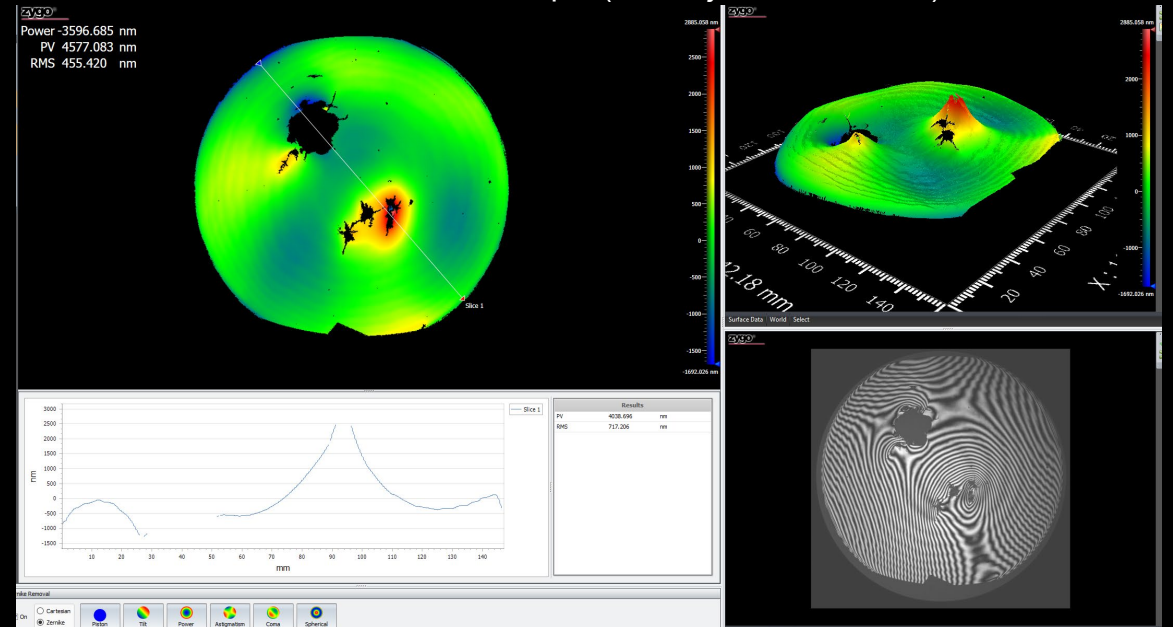

Key Architecture Assumption: Full Barrel Provides Mitigations

WFE and Coronagraph:

- Infrequent higher energy hits – Large WFE change (eg, JWST C3)
- Low- Medium energy hits – Longer term WFE degradation
- Coronagraphic Performance: Correctability/throughput and dynamic range of DM.
- Constant small instabilities (“pings”) – Sudden vibrations that can impact contrast

Other Considerations:

- Contamination during servicing/protection
- Contamination protection from thruster/micro-thruster exhaust
- Potential protection from sunlight/photopolymerization during launch and ascent (if partial barrel)
- Straylight protection – out of field stars and Zodi, etc

NOTIONAL EXPLORATORY ANALYTIC CASES

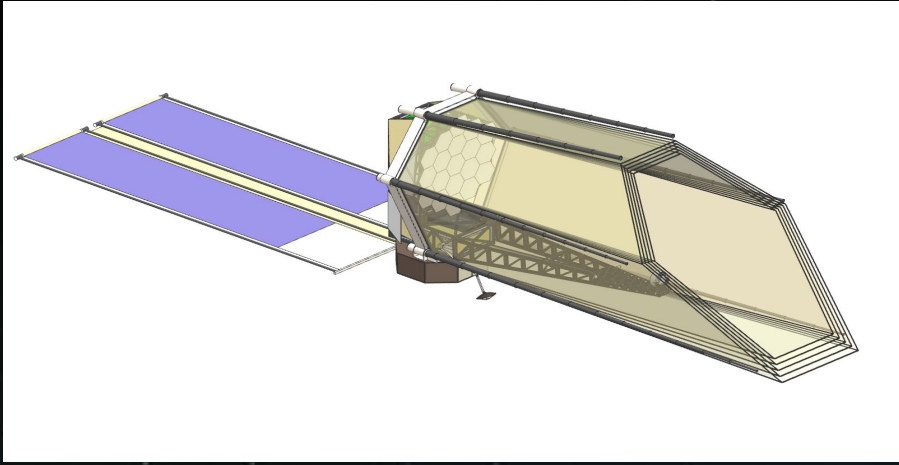

EAC1:

6m ID/7.2m OD off-axis

19 hex segments

PM faces horizontal in rocket

JWST like wing deployment

Fits in New Glenn, Starship

Standard

Low Areal Density Mirrors

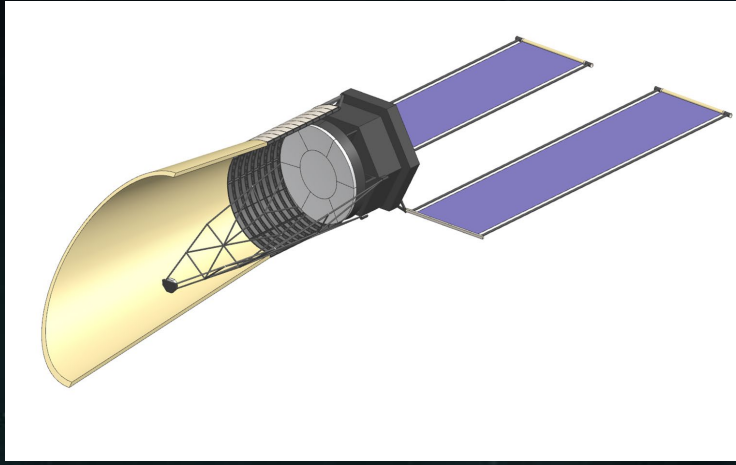

EAC2:

6m ID (round) off-axis

Non-deployed Primary mirror

- Central 3 m round mirror + 6 keystone

PM faces up in rocket

Lower barrel is fixed, upper barrel and SM deploy

Fits in Starship Standard

Higher Areal Density Mirrors

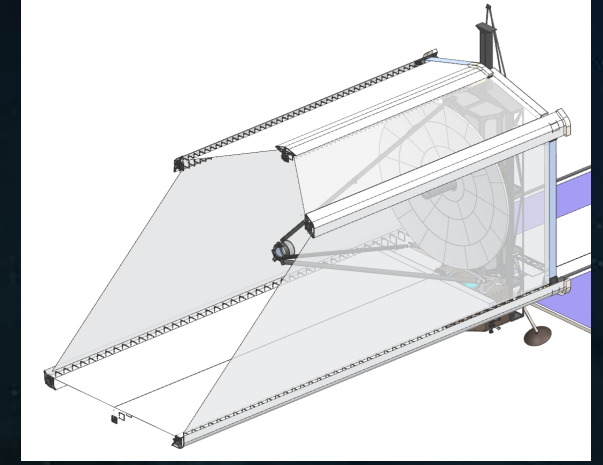

EAC3:

8m ID (round) on-axis

34 keystone segments

PM Faces horizontal in rocket

JWST like wing deployment

Fits in Starship Standard

Low Areal Density

Large FOV guider/active wavefront sensing and control

OVERALL EAC STATUS

- EAC1 Design efforts completed June 1st
 - General approach has been to start with passive designs and then evaluate active options
 - Thermal, isolation
 - Design is not optimized and has some liens but we believe is sufficiently mature to move onto integrated modeling
 - Key goal is to do end to end modeling up to yield calculations
- Next step for EAC1 is to start integrated modeling
 - STOP, Dynamics, Thermal Stability, Coronagraphic performance
- Will move design team over to EAC2 and 3, some level of overlapping efforts
- On track to have EAC1, 2, 3 designs complete by CML3 in March 2025
- On track to have at least EAC1 end to end modeling complete by CML3 and EAC 2 and 3 finishing up during the transition period of CML3 to CML4

EAC-1 CONCEPT SUMMARY

EAC-1 Stowed Configuration

EAC-1 Deployed Configuration

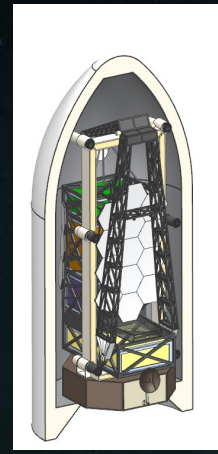
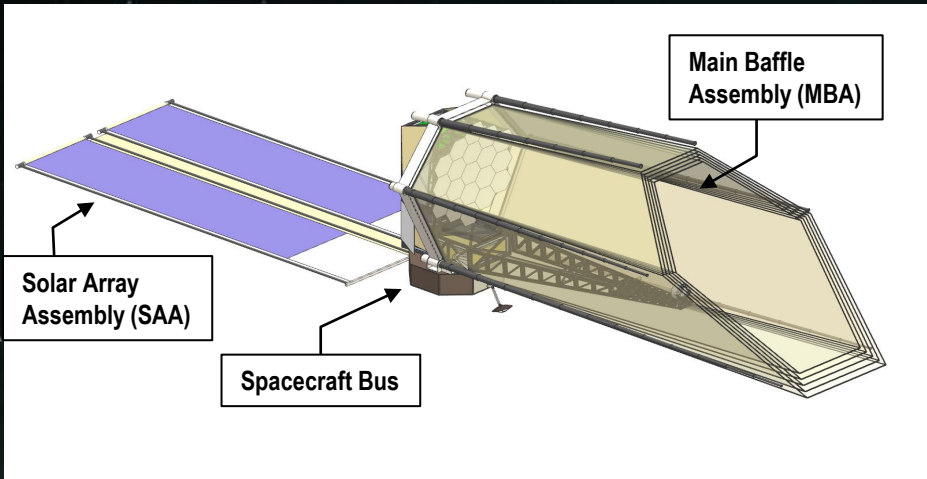

SLS Short Fairing



Starship Standard Fairing



New Glenn Standard Fairing

EAC-1 Deployment Concept

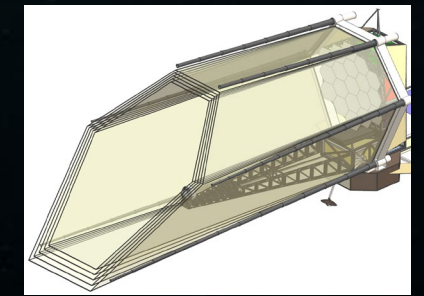
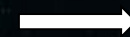
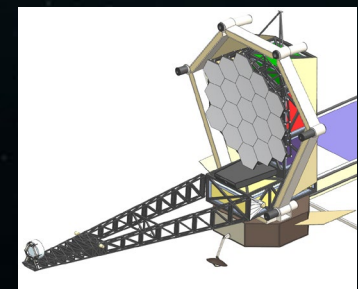
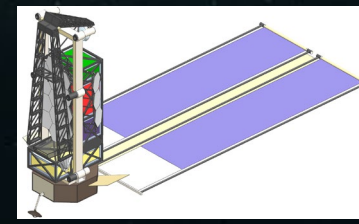
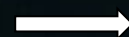
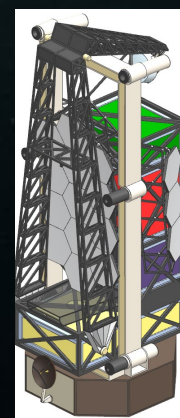
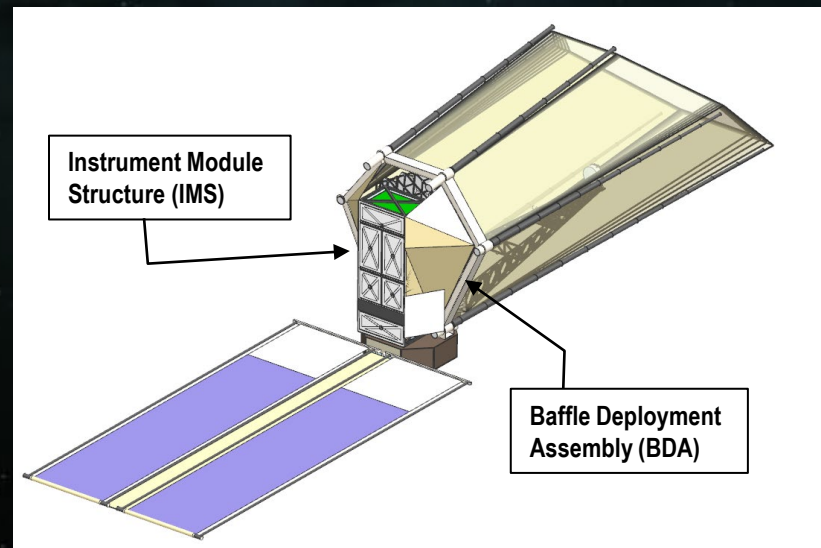

SOME KEY FINDINGS FROM EAC1 DESIGN WORK

- Volume for coronagraph was challenging
 - Assumed CGI-like 1mm pitch AOX DM (Boston MEMS DM is .4mm pitch)
 - Was able to package with extra fold, but large volume used
- Accommodation of NIR Coronagraph Detectors is challenging and current heat sink temperatures are marginal (goal of 50K, 65K is hard cutoff)
 - Assumes photon counting HgCdTe APD
 - Drove us to large deployed shades to avoid back loading, lessons learned on configuration
 - Zero vibration cooler would be an option
- Complexity and stability of the Main Barrel Assembly is still being assessed
 - Number of layers, some heaters to be studied
- Observatory mass will exceed the New Glenn current capabilities
 - Deployed stiffness “goals” of the backplane exacerbate mass challenge for EAC1
- Great teamwork across NASA centers, Habex+LUVOIR!!!

PARAMETRIC STUDIES: EXAMPLES

Study	Description	Input	Output	Group	Thread Lead	Reporting Forum	Status	Proposal Status
Polarization study vs large angle fold (e.g. 90 deg fold) between secondary mirror and coronagraph.	<p>EAC1 is being designed with the coronagraph positioned to the side of the telescope, along the secondary tower, to avoid having a large angle fold in the beam train prior to the coronagraph. This could limit coronagraph volume and create thermal issues. Is it acceptable to have a large angle fold, or pair of folds, between the secondary mirror and the coronagraph, so that the coronagraph could be placed behind the telescope? One possibility would be to collimate the beam prior to folding. Then the fold would not introduce polarization aberrations. If there is a means to use < 90 deg folds, then also study of residual leakage vs. fold angle.</p> <p>A related study is: how do we split the beams between the multiple coronagraphs. Do we need to avoid large angle folds at the polarizing beamsplitters or dichroic beamsplitters? We have never implemented a coronagraph in this way.</p> <p>The criterion for 'acceptable' is the residual leakage (contrast) caused by folds. A reasonable criterion might be to limit the residual polarization leakage at the IWA to 1e-11 TBR.</p>	EAC1 telescope optical design, coronagraph design with nominal baseline coronagraph (VVC-6 ?). This study requires polarization ray tracing, and a table of coronagraph aberration sensitivity.	Residual leakage generated by large angle folds.					Submitted by Stuart
Polarization Sensitivity vs Angle of Incidence	<p>Polarization aberrations can be very problematic for coronagraphy. Changes in angle of incidence across a beam results in changes in the complex amplitude of orthogonal polarization states, which are low spatial order. This study will build on work already implemented by Jaren Ashcraft in his Ph.D thesis to parametrize contrast performance vs. cross-polarization corruption vs. angle of incidence. This work will iterate over (1) angle of incidence; (2) possible coatings that will be used on the OTA and the coronagraph instrument; and (3) coronagraph mask. Ultimately, we will understand how polarization aberrations affect coronagraph masks and trace those back to science yield via ExoSIMS and AYO.</p>	EAC1 telescope optical design with varied M1/M2 angles of incidence, a notional coronagraph instrument design with variable M3/M4 positions, coronagraph mask candidates (from CDS?), and coating candidate recipes (from M. Quijada et al.)	Contrast curves, yields, Jones matrices	Coronagraph Coordination	Breann Sitarski	Coronagraph Coordination HWO-TAG WG		

PARAMETRIC STUDIES

- Team has developed a parametric study matrix that covers the many analyses that need to be studied, this is kept in a multi-page spreadsheet on Box in the START TAG Systems Folder
 - Example: While EAC1 will start with a particular coronagraph type and mask design, a proposed parameter study is to study 20 different design options using the EAC1 aperture
- Parametric studies are written up as Parameter Study Design Descriptions which describes the analysis proposed, resources, reasons it is a priority to do now, etc
- Parametric studies are reviewed by the leadership team, prioritized, and tracked
- Once complete, a final Parameter Study report is written

KEY TECHNOLOGIES FOR HWO (DRAFT)

Technology	Needed for TRL 5	Threshold	Baseline	Enhancing	Current TRL (TBR)
Coronagraph architecture/masks	1e-10 contrast, >10% bandwidth, over specified IWA-OWA, with segmented ap	X			3-4
Deformable Mirrors	Ideally 96x96 actuators, stable/low creep, robust electronics	X			4
Coronagraph Sensing & Control (LOWFS/OBWFS/HOWFS)	Stabilize contrast to necessary level over specified bandwidth	X			3-5
Low-noise, photon-counting visible detectors	Low dark current, rad-hard detectors; enhanced red-edge QE	X			4
Ultra-stable mirror segments	Stiff, lightweight segment with thermal stability diffraction-limited performance	X			3-5
Segment rigid-body actuation	Low-creep, large stroke actuators with picometer resolution	X			3
Telescope wavefront sensing & control	Segment rigid-body sensing and global alignment sensing to picometer level	X			3-4
Deployable Membrane Baffle	Robust to micrometeoroids, low complexity deployment	X			3
Vibration Isolation / Low Disturbance Mechanisms	~40 dB isolation/suppression of disturbances > 1 Hz	X			4
Far-UV mirror coatings	>50%-80% reflectivity 100-110 nm, robust to environments, no impact to coronagraphy	?	?		4
Low-noise, photon-counting NIR detectors	Photon-counting performance in NIR; rad-hard	?	?		3
Large-format, low-noise NUV/Visible detectors	8k x 8k format, low-noise, enhanced blue-edge QE		X		4
Enhanced Far-UV detectors	>40% QE 100-200 nm; large format, high-out-of-band rejection		X		4-6
Next-generation Microshutter Arrays	<100 mas spatial resolution, >500 simultaneous objects		X		3
NUV High Contrast Technology	Achieves necessary contrast between 200-350 nm			X	2
Ultrastable metrology and test capabilities	Facility and metrology for testing <1mK optics and structures to picometer levels	X			NA

To be discussed at the Technology Splinter

One Year Top-Level Milestones Schedule

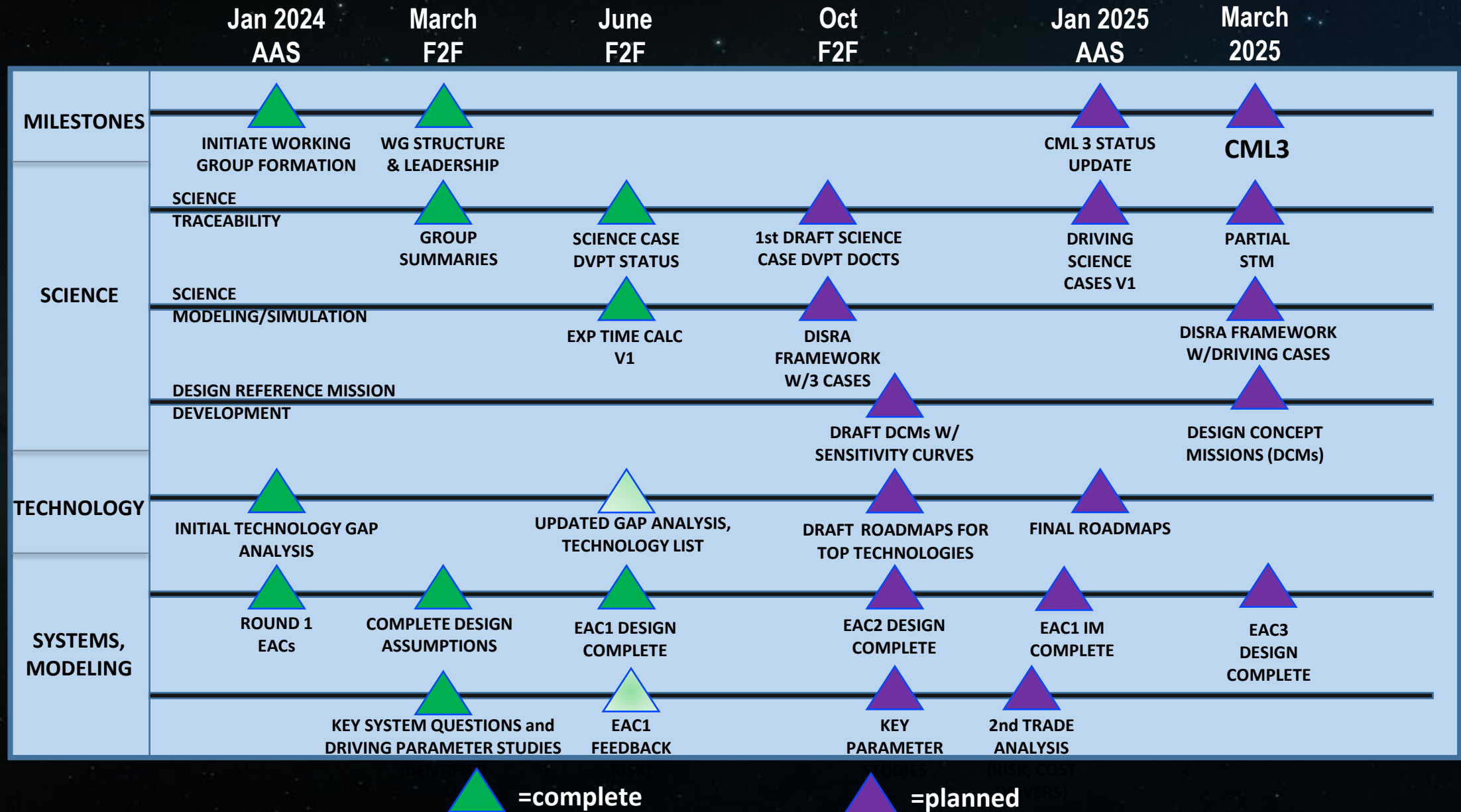

 =complete

 =planned

HWO IS ALREADY A TEAM EFFORT WITH CONTRIBUTORS FROM AROUND THE WORLD

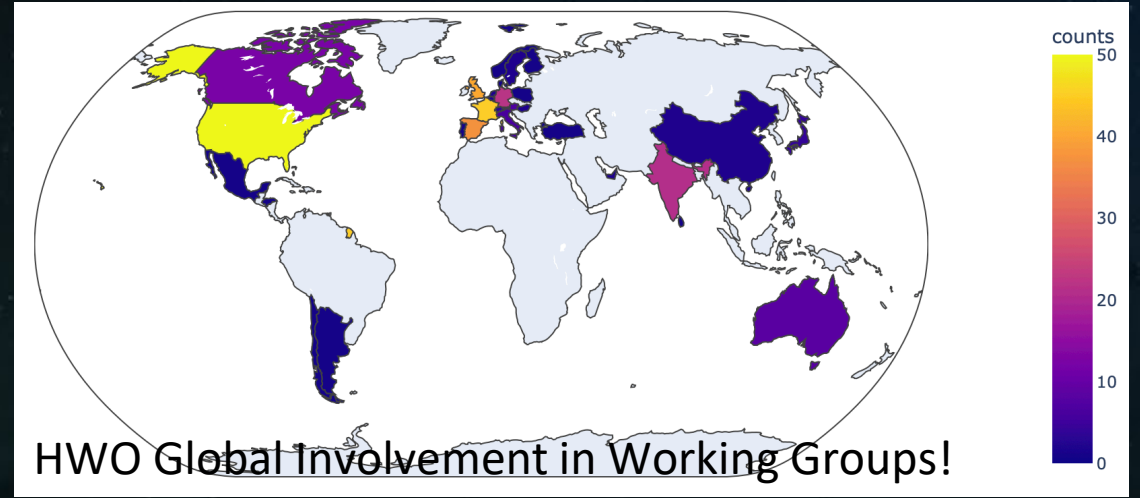

HWO Global Involvement in Working Groups!



Jan 2024 AAS Meeting

Now ~~Outdated!~~
<https://science.nasa.gov/astrophysics/programs/habitable-worlds-observatory/>



Sign up for the *mailing list* on the
NASA HWO website!